



Submersible Axial Flow Pump

Excellence – Life – Environment Concern

INTRODUCTION

DAF series axial-flow pumps are modern productions successfully designed by the means of adopting foreign modern technology. The new pumps' capacity is 20% larger than the old ones. The efficiency is 3-5% higher than the old ones.

DAF series pump with adjustable impellers has the advantages of large capacity, broad head, high efficiency, wide application and so on.

WORKING CONDITIONS

Medium grade pure water of no larger than 50°C

APPLICATIONS

DAF Series axial flow pump application range: Water supply in cities, industrial uses, sewage drainage systems, sewage disposal projects, etc.

STRUCTURE DRAWING

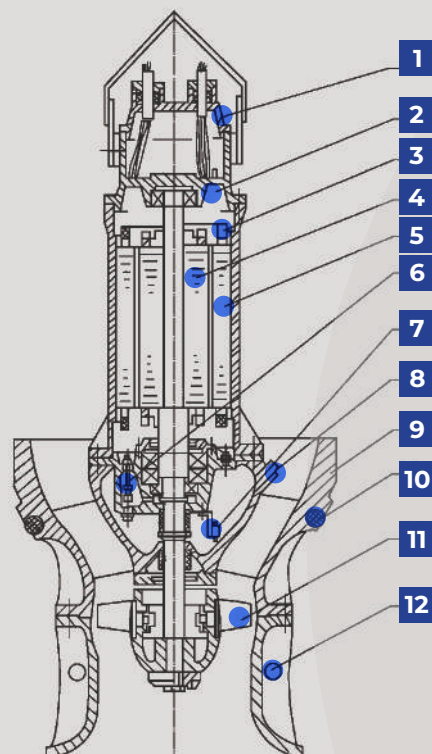

1	Junction
2	Leakage probe
3	Heat protector
4	Rotor
5	Stator
6	Leakage alarm
7	Oil-water probe
8	Oil filler
9	Guide vane
10	Seal ring
11	Impeller part
12	Suction bell

GENERAL DESIGN

Material

Impeller Material	Stainless Steel 304 - 316 - Duplex
Shaft Material	Stainless Steel 420
Pump Case Material	Gray Iron Casting 250
Motor Case Material	Gray Iron Casting 250
Cable Hold Material	Stainless Steel 304 - 316 - Duplex
Wearing Ring	Stainless Steel 304 - 316 - Duplex
No. of Blades	4 blades
Cables	10 m
Insulation Class	IP68, Class F

Monitoring System Sensors Type

PT100 at stator winding
PT100 at upper & lower bearing
Leakage Sensor
Float switch in stator housing
Moisture sensor

INSTALLATION DRAWING

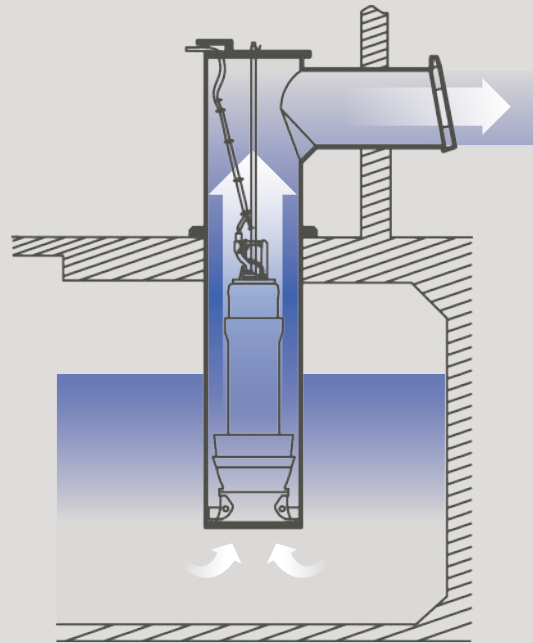

PERFORMANCE CURVES

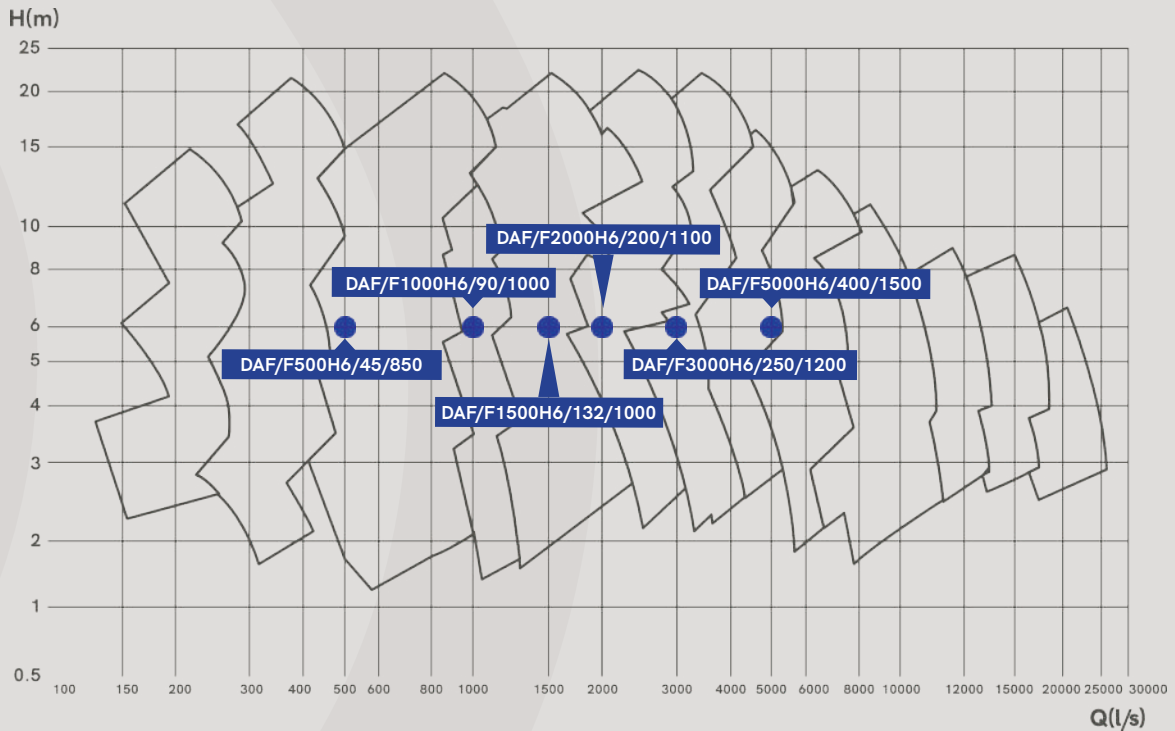

Type	Capacity (l/s)	Capacity (m ³ /h)	Head (m)	Power (kW)	Motor Output (HP)	Rated Current (A)	Column Size (mm)
DAF/F500H6/45/850	500 m ³ /s	1800 m ³ /s	6 m	45	60	100	850
DAF/F1000H6/90/1000	1000 m ³ /s	3600 m ³ /s	6 m	90	120	184	1000
DAF/F1500H6/132/1000	1500 m ³ /s	5400 m ³ /s	6 m	132	180	272	1000
DAF/F2000H6/200/1100	2000 m ³ /s	7200 m ³ /s	6 m	200	270	398	1100
DAF/F3000H6/250/1200	3000 m ³ /s	10800 m ³ /s	6 m	250	335	517	1200
DAF/F5000H6/400/1500	5000 m ³ /s	18000 m ³ /s	6 m	400	540	867	1500

FEATURES

1

**Save Electricity
Energy Up To 25%**

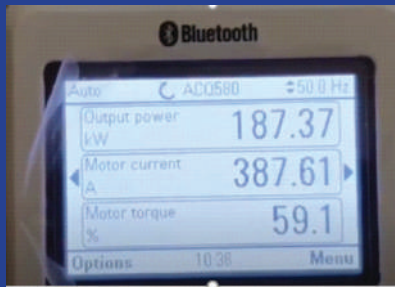

2

Low noise level



3

High insulation



4

Low vibration



5

Complete service and maintenance modules

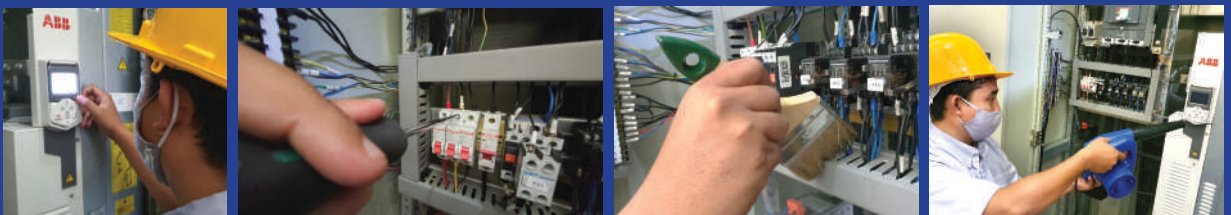

PT. POMPA DEX INDOGUNA



Office :

Ruko Park Way No. 92,
Pakuwon City, Surabaya - Indonesia

P. 031 5953 529

E. support@dexindonesia.com

www.dexpump.com

 **DEX Pump Indonesia**